

OSA 5130 Active Noise Filter

A compact, cost efficient, high quality Active Noise Filter synchronization solution for T&F applications

Introduction

The OSCILLOQUARTZ 5130 Active Noise Filter with patented BVA technology integrates the type of filter already present in Oscilloquartz' highly successful top-of-the-line OSA 5581C GPS-SR and 453x GPS-SB series, built into a 2U-high, 19" sub-rack format, complete with an integrated power supply (20-60V).

The OSA 5130 Active Noise Filter provides 1 low noise output at 5 MHz (-125 dBc @ 1Hz) or 10 MHz (-115 dBc @1Hz).

The OSA 5130 Active Noise Filter incorporates a highly accurate BVA double-oven-controlled oscillator, which filters the input reference signal and provides a stable frequency reference on stand alone (typ. 1×10^{-11} /day) or a low noise, filtered signal, presenting the short term BVA performance and low term stability of references.

Management Software:

The OSA 5130 Active Noise Filter can be managed by any Windows based PC connected to the equipment via an RS-232 connection and running the Configuration and Monitoring software (CMSW).

Functions

The CMSW application provides an intuitive, easy-to-use access for configuring the unit and examine its current status.

The unit also provides an alarm relay contact allowing existing communication system to retrieve basic status information.

The OSA 5130 can be managed by the SyncView™ Plus synchronization network management system for alarm reporting and control functions with Universal Module Interface (UMI).

OSA 5130 Active Noise Filter Block Diagram

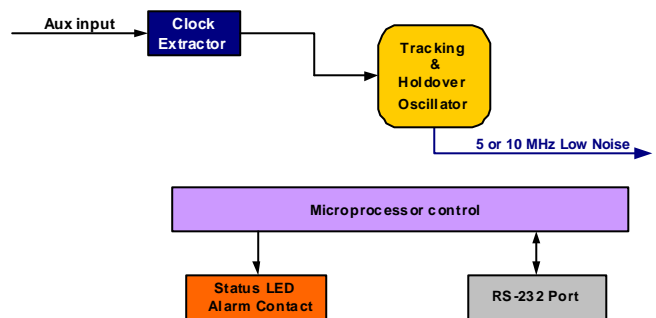

Highlights

- Reliable, low cost, Active Noise Filter
- Input: E1, 64kHz, 2.048, 5, 10 MHz frequency
- Output: 5 or 10 MHz
- BNC connectors for all inputs and outputs
- Integrated high stability holdover functionality:
 - ITU-T G.812 (I, V, VI) compliant holdover
 - ITU-T G.812 (I, V, VI) filtering of auxiliary input

Typical Applications

- Noise filtering of Atomic Clocks (Rb, Cs) and GNSS receivers
- Frequency reference for test equipment and instruments
- Satellite ground stations equipment
- Frequency reference for metrology laboratories
- Any systems requesting highly accurate frequency reference
- VHF broadcasting system

OSA 5130 Active Noise Filter

A compact, cost efficient, high quality Active Noise Filter synchronization solution for T&F applications

Typical Characteristics

Power supply:

- 20-60 VDC
- Consumption: < 20W during warm-up, < 15W steady state 25°C

Configuration and Monitoring software:

- Runs on any IBM-compatible PC with Windows 98/NT/2000/XP

Holdover performance:

- Long term stability: $2 \times 10^{-11}/\text{day}$, $4 \times 10^{-9}/\text{year}^*$
- Frequency stability: < 2×10^{-10} pp (-5°C to +55°C)

Physical dimensions:

H x W x D (mm) : 89x483x280mm (3.5"x19"x11")

Input signals:

- E1
- 64kHz, 2.048, 5, 10 MHz: 0.5 V rms sine, 50Ω

Output signals:

- 5 or 10 MHz, 0.5 V rms sine, 50Ω

Management:

- RS-232C connector
- 1 x Relay contact

Environmental characteristics:

- Operational: -5°C to +55°C
- Storage: -40°C to +85°C
- Humidity: 95% non-condensing

5 MHz

- Phase noise**:

1Hz:	-125 dBc
10Hz:	-145 dBc
100Hz:	-150 dBc
1kHz:	-155 dBc
10kHz:	-155 dBc
100kHz:	-155 dBc

- Harmonics: $\leq -40\text{dB}$
- Non-Harmonics: $\leq -70\text{dB}$
- Output : 1x5MHz at 50Ω
- Amplitude: 7dBm at $\pm 1\text{dBm}$
- Frequency Holdover: $2 \times 10^{-11}/\text{day}^*$
- Temperature sensitivity (frequency): 2×10^{-10} (-5°C to +55°C)

10 MHz

- Phase noise **:

1Hz:	-115 dBc
10Hz:	-135 dBc
100Hz:	-140 dBc
1kHz:	-145 dBc
10kHz:	-145 dBc
100kHz:	-145 dBc
- Harmonics: $\leq -40\text{dB}$
- Non-Harmonics: $\leq -70\text{dB}$
- Output : 1x10MHz at 50Ω
- Amplitude: 7dBm at $\pm 1\text{dBm}$
- Frequency Holdover: $2 \times 10^{-11}/\text{day}^*$
- Temperature sensitivity (frequency): 2×10^{-10} (-5°C to +55°C)

Stability: Tracked on ideal reference

Allan Deviation	
τ	$\sigma_y(\tau)$
1s	$< 8 \times 10^{-13}$
10s	$< 8 \times 10^{-13}$
100s	$< 1 \times 10^{-12}$

*after 30 days of continuous operation.

** Holdover mode or locked on OSA 5585B PRS

Oscilloquartz SA reserves the right to change all specifications contained herein at any time without prior notice.

A COMPANY OF THE SWATCH GROUP

